

# SPECIFICATION

## FULL CIRCLE<sup>®</sup> REDI-CLAMP<sup>®</sup>

### MODEL 244

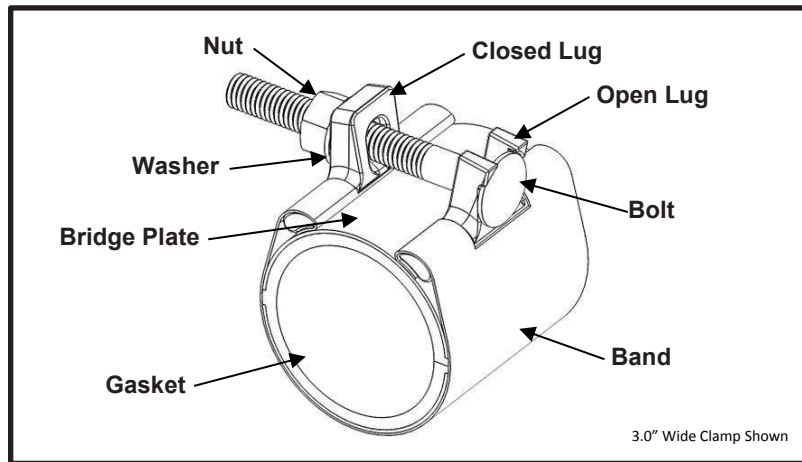

#### APPLICATIONS

- **Typical Uses**

- Repair leaks due to complete breaks, splits, or holes
- Joining pipes of the same diameter
- Examples:

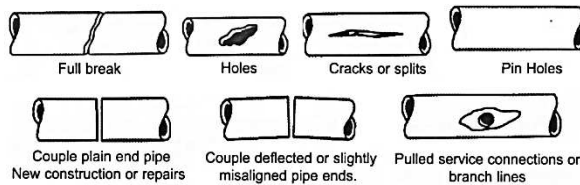

- **Standard Pipe Sizes**

- 0.5" to 2" nominal

- **Standard Widths**

- 3.0", 6.0", 12.0"

- **Type of Pipe**

- Carbon Steel, Ductile Iron, Stainless Steel, PVC, Copper

- **Working Pressure**

- Up to 150 psi depending on type of pipe, type of repair, pipe diameter, service conditions, and installation workmanship

#### MATERIALS

- **Band**

- Type 304 Stainless Steel per ASTM A240
- Band Thickness: 24 gauge
- Formed to pipe O.D. and secured to lug body

- **Lug**

- Cast using Ductile Iron 65-45-12 per ASTM A536
- Flexi-Coat<sup>®</sup> fusion bonded epoxy finish
- Designed for drop in replaceable bolts
- One open loop lug and one closed loop lug. The bolts do not have to be removed to install clamp preventing lost hardware
- Precision cast with contoured surface to equalize clamping pressures around the pipe



# SPECIFICATION

## FULL CIRCLE<sup>®</sup> REDI-CLAMP<sup>®</sup>

### MODEL 244

- 
- **Gasket**
    - Nitrile (Buna-N) per ASTM D2000
    - Gasket Thickness: 0.25"
    - Certified to NSF/ANSI 61-G & 372
    - Compounded to resist water, oil, natural gas, acids, alkalies, most (aliphatic) hydrocarbon fluids, and many other chemicals
    - Temperature range: -20°F to +180°F
    - Full 360° smooth face gasket provides maximum pipe support, reinforcement, and sealing pressure
  - **Bridge Plate**
    - 18-8 quarter-hard Type 304 Stainless Steel per ASTM A240
    - Two plates recessed flush and bonded into gasket
    - Preformed for uniform distribution of gasket pressure over the entire pipe circumference
  - **Bolt**
    - Material: 0.5" – 1.5" nominal pipe size = Carbon Steel SAE J249 GR2  
2.0" nominal pipe size = Carbon Steel SAE J249 GR5
    - Fe/Zn coated per ASTM F1941-10
    - Size: 0.5" – 1.5" nominal pipe size = 3/8"-16UNC x 3.00" long, Round Head Square Neck  
2.0" nominal pipe size = 7/16"-14UNC x 4.00" long, Round Head Square Neck
    - Rolled threads for improved physical characteristics, greater thread accuracy, and smooth surface finish
    - Drop in replaceable bolts
  - **Nut**
    - Carbon Steel per ASTM A307
    - Fe/Zn coated per ASTM F1941-10
    - Size: 0.5" – 1.5" nominal pipe size = 3/8"-16UNC Heavy Hex  
2.0" nominal pipe size = 7/16"-14UNC Heavy Hex
  - **Washer**
    - Carbon Steel per ASTM A108
    - Fe/Zn coated per ASTM F1941-10
    - Size: 7/16" Type A Plain

#### LISTINGS

- Certified to NSF/ANSI 61-G & 372

#### OPTIONS

- Type 316 Stainless Steel band
- Type 304 Stainless Steel hardware with fluoropolymer coated nuts to prevent galling
- Type 316 Stainless Steel hardware with fluoropolymer coated nuts to prevent galling
- Alternative gasket material (e.g. Viton, EPDM, etc.)



# SPECIFICATION

## FULL CIRCLE<sup>®</sup> REDI-CLAMP<sup>®</sup>

### MODEL 244

---

#### NOTES

- This product **does not** restrain the pipe from pulling out of the fitting
- Pipe stiffeners **are required** when this product is used for joining thin wall PVC pipe
- Clamp may be used for most water and gas applications with the exception of gas plastic pipe repair. It is suitable for restoring shape and marking crimped polyethylene gas service lines.
- Full Circle<sup>®</sup> and Redi-Clamp<sup>®</sup> are registered trademarks of Smith-Blair Inc.
- These product specifications were correct at the time of publication and are subject to change without notice
- See the Smith-Blair<sup>®</sup> web site for part numbers and ordering information
- See the Smith-Blair<sup>®</sup> web site for warranty information
- See the Smith-Blair<sup>®</sup> web site for corrosion warnings

30 Globe Ave, Texarkana, AR 71854  
Ph: 870-773-5127 • Fax: 870-773-5212  
Toll-Free Numbers: Ph: 800-643-9705 • Fax: 800-648-6792

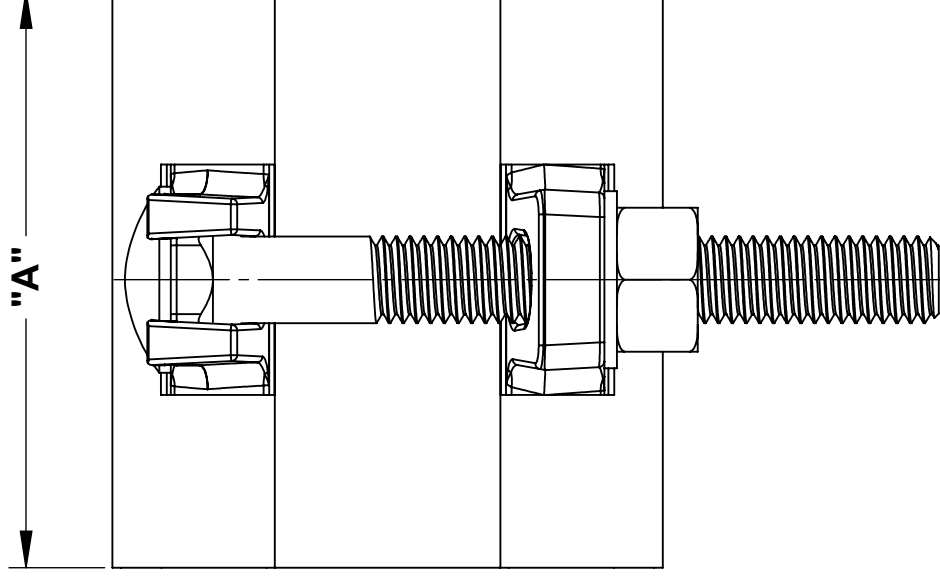
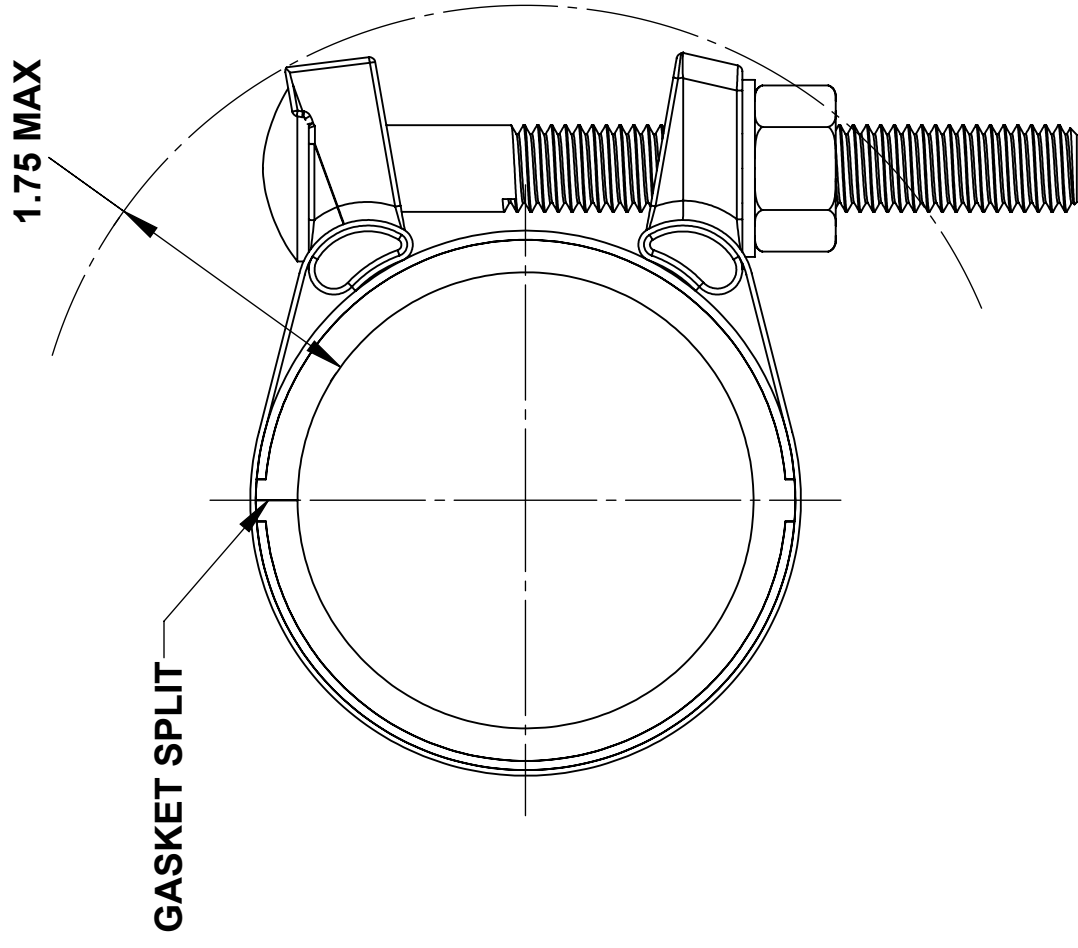

- NOTES:**
- SEE SMITH-BLAIR CATALOG FOR AVAILABLE PIPE DIAMETER AND WIDTH COMBINATIONS AS SOME COMBINATIONS ARE NOT AVAILABLE
  - 3.00" WIDE CLAMP SHOWN OTHER SIZES SIMILAR

**CERTIFIED TO NSF/ANSI 61-G & 372**

NOMINAL PIPE SIZE	A	HARDWARE		SOCKET SIZE
		QUANTITY	SIZE	
0.5 - 1.50	3.00	1		1 1/16"
	6.00	2	3/8" x 3"	
	12.00	4		
2.00	3.00	1		3/4"
	6.00	2	7/16" x 4"	
	12.00	4		

TOLERANCES U.N.O. XX= ±.03 XXX= ±.015 FRACTIONS= * ANGLES= ±1° MACH. FIN=	NOTES: REMOVE BURRS AND SHARP EDGES DO NOT SCALE DWG.	APP'D	DATE
	SCALE: N/A	CK'D	DATE
	ALL DIMENSIONS ARE IN INCHES.	DRN	DATE

**TITLE**  
**SPECIFICATION**  
**FULL CIRCLE® REDI-CLAMP®**  
**MODEL 244**

<b>SMITH-BLAIR, Inc.</b> TEXARKANA, ARKANSAS	P/N	N/A
<b>SPEC_244.DRW</b> DWG. NO.	1 OF 1 SHEET	2/19/16 REV.